

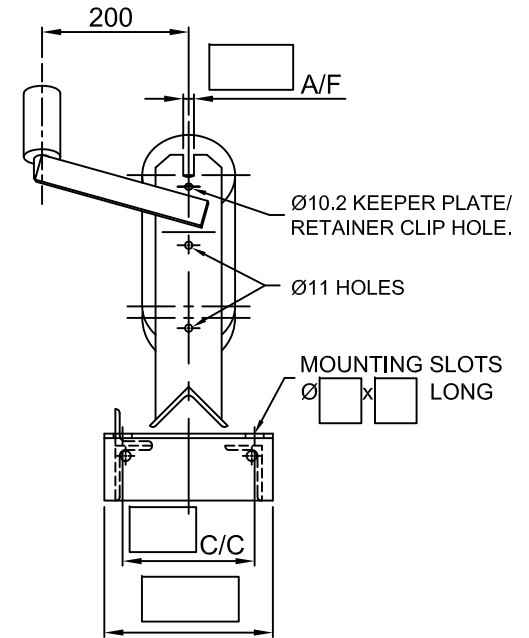

RKM INTERNATIONAL LTD
 ROOM SUITE 2203, 22/F, OFFICE TOWER, LANGHAM PLACE
 8, ARGYLE STREET, MONGKOK
 KOWLOON, HONG KONG

THIS DRAWING AND ASSOCIATED CAD FILE REMAINS THE PROPERTY OF RKM INTERNATIONAL LTD
 AND MUST NOT BE COPIED OR REPRODUCED IN ANY FORMAT WITHOUT WRITTEN PERMISSION FROM THE OWNER

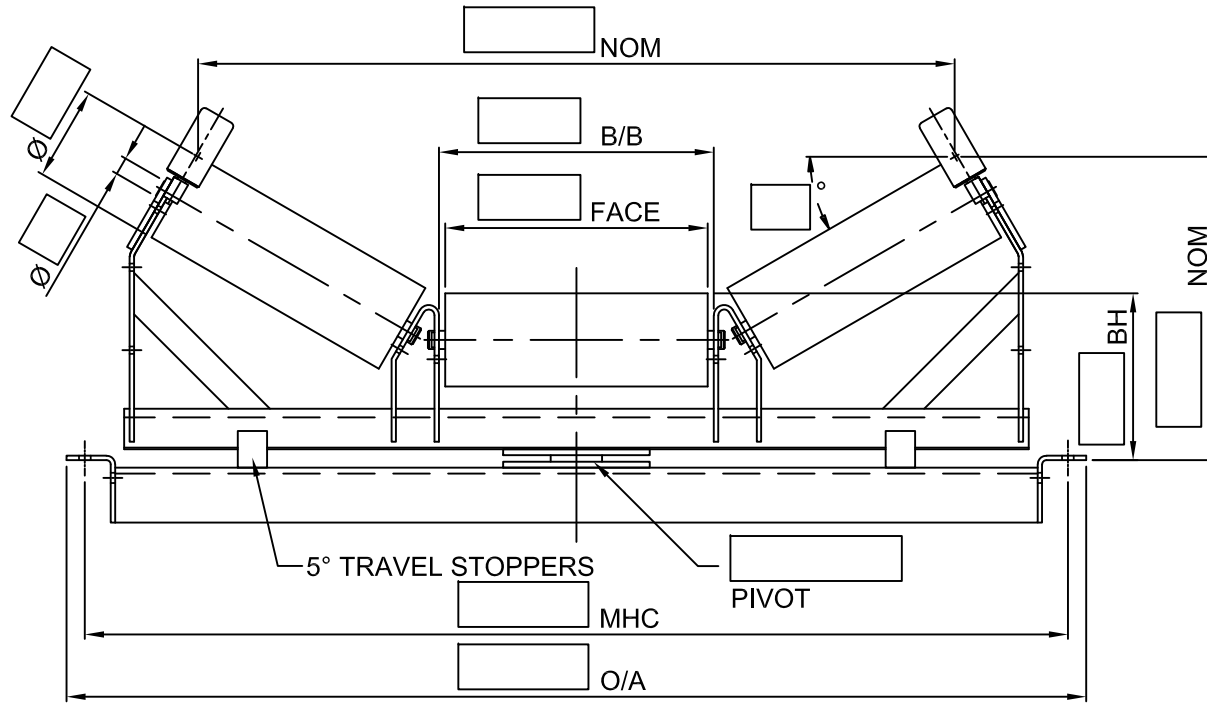

NOTES:

1. ROLLER ENDS TO BE PAINTED RED ENAMEL.
2. FOR STANDARD MATERIALS SPECIFICATIONS, REFER RKM CATALOGUE.
3. FRAME MATERIAL - ASNZS 3679.1-250 OR EQUIVALENT.
4. REMOVE ALL SHARP EDGES AND BURRS.
5. FRAME TO BE HOT DIPPED GALVANIZED TO ASNZ-4680 OR EQUIVALENT.
6. FOR STANDARD DIMENSIONAL TOLERANCES, REFER RKM CATALOGUE.

SERIES			
BEARING	NUMBER :	RATING :	
SHAFT	Ø / Ø / Ø		
MASS	ROTATING :	kg	TOTAL : kg

ALL DIMENSIONS IN MM
 UNLESS NOTED
 OTHERWISE

DO NOT SCALE

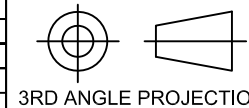

DATE DRAWN	DRAWN BY	CHECKED	APPROVED BY	DATE	MATERIAL
PROJECT: -					MASS
TITLE: 3 ROLL ____° INLINE TROUGH TRAINING IDLER ____mm BELT WIDTH					
PART NO.			REVISION	SCALE(S)	SIZE
			0	NTS	A4
					SHEET
					1 / 1

REVISION					
ZONE	REV	DESCRIPTION	BY	DATE	
-	-	-	-	-	
-	-	-	-	-	
-	-	-	-	-	
-	-	-	-	-	